

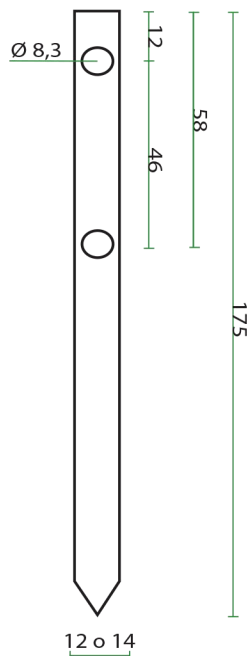

STACCIONATE

Le staccionate si realizzano con i pali ed i mezzi pali torniti e l'ausilio di pezzi speciali di seguito riportati. I pali ed i mezzipali sono realizzati in pino silvestre impregnato in autoclave. I nodi e le fenditure longitudinali riscontrabili nei pali costituiscono una caratteristica tipica del legno e non ne compromettono la resistenza e la stabilità.



PALI PINO TORNITI 2 FORI Ø 8
Ø 14x175 - Ø 12x175

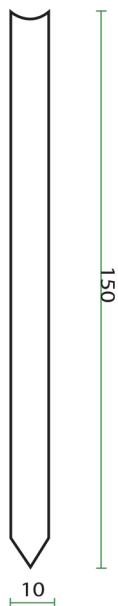

PALI PINO TORNITI CON SELLA
Ø 10x150



VITE DUOFIX 100 PZ.
Ø 5x60 - 6x80 - 6x100 - 6x120 - 6x140
6x160 - 6x180 - 10x220



FASCETTA IN RAME
3,8x50

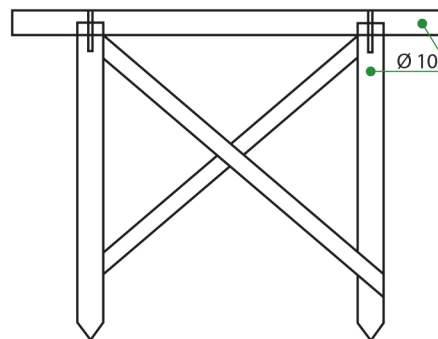

ANCORAGGIO PALO ROTONDO
zinc. a pavimento Ø 8-10-12



ANCORAGGIO PALO QUADRATO
zinc. su terreno cm 9x9 H 50



ANCORAGGIO PALO QUADRATO
zinc. a pavimento cm 9x9



ANGOLARE STACCIONATE
80x120



ANGOLARE STACCIONATE
60x120